

Anal. Calcd. for $C_{24}H_{34}O_2$: C, 83.23; H, 6.99; mol. wt., 490.6. Found: C, 83.16; H, 7.18; mol. wt., 561.

A second portion of the concentrate, after being recrystallized from methanol, melted at 93–95°; infrared spectrum chloroform solution: 8.65, 9.00, 931 and 9.66 μ , no OH, NH or C=O.

Anal. Calcd. for $C_{15}H_{20}O_2$: C, 80.56; H, 7.51. Found: C, 80.66; H, 7.30.

3,3-Diphenyl-5-methyl-2-ethylidenetetrahydrofuran.—The reaction was run as in the preparation of III. After the

reaction had been completed the mixture was poured into 6 *N* hydrochloric acid. The mixture was extracted with ether, the ether layer washed with water and then with dilute sodium bicarbonate solution, dried over magnesium sulfate and concentrated. The residue was recrystallized from methanol, m.p. 79–80°; mixed m.p. with authentic sample⁴ 79–80°.

INDIANAPOLIS, INDIANA
BETHLEHEM, PENNA.

[CONTRIBUTION FROM THE PHARMACEUTICAL INSTITUTE, MEDICAL FACULTY, UNIVERSITY OF KYUSHU]

Stereochemistry of the 2,2'-Dihydroxydicyclohexylamines. I¹

BY TANEZO TAGUCHI AND KEN HAYASHIDA

RECEIVED AUGUST 7, 1957

meso-trans-trans-2,2'-Dihydroxydicyclohexylamine (I) has been converted to the *dl-trans-cis*-epimer II via the Walden inversion of its *N*-benzoyl derivative VII by thionyl chloride; VIII, the *N*-benzoyl derivative of II, yields the *cis-cis*-epimer III upon similar treatment. In the reaction of the *N*-benzoyl *meso-trans-trans*-epimer VII with thionyl chloride, *dl*-3-(*trans*-2'-hydroxycyclohexyl)-2-phenyl-*cis*-4,5-cyclohexanoöxazolium chloride (X) was isolated as an intermediate; X also was obtained by treatment of the *N*-benzoyl *dl-trans-cis*-epimer VIII with dry hydrogen chloride. It was found that *N*-benzoylation was inhibited in those dicyclohexylamines which contained a *cis*-hydroxy group.

Examination of the formula for 2,2'-dihydroxydicyclohexylamine reveals the possible existence of

of *meso-cis*-cyclohexene oxide with ethanolic ammonia. Much later Mousseron and his co-workers⁴ repeated Brunel's work and suggested that these compounds were the *meso-trans-trans*- and *dl-trans-trans*-isomers on the basis of the known *trans* opening of the *cis*-oxide ring. They were unable to classify the two *trans-trans*-isomers by means of optical resolution. However, when *cis*-cyclohexene oxide reacted with either *d*-*trans*-2-aminocyclohexanol or its antipode, they obtained *d*- or *l*-*trans-trans*-2,2'-dihydroxydicyclohexylamine (m.p. 115°), respectively, and *meso-trans-trans* 2,2'-dihydroxydicyclohexylamine (m.p. 153°); thus the isomer of the m.p. 115° is the *dl*-form IV, and that of m.p. 153° is the *meso*-form I. We are investigating the other four stereoisomers which have not previously been reported, and have synthesized the *dl-trans-cis*- (II) and *meso-cis-cis*-epimer (III) from *meso-trans-trans*-2,2'-dihydroxydicyclohexylamine (I).

dl-trans-cis-2,2'-Dihydroxydicyclohexylamine (II) was prepared as follows; see Chart II. The *N*-benzoyl derivative VII of the *meso-trans-trans*-aminodiol I was obtained by the treatment of *meso-cis*-cyclohexene oxide with aqueous ammonia, followed by Schotten-Baumann benzoylation. This *N*-benzoyl derivative VII, m.p. 232°, was converted to VIII, m.p. 197°—the *N*-benzoyl derivative of another, 2,2'-dihydroxydicyclohexylamine—by reaction with thionyl chloride, followed by treatment with aqueous sodium hydroxide. The new *N*-benzoyl derivative VIII was converted to a free aminodiol II, m.p. 147°, via its hydrochloride IX. The same aminodiol II was obtained by the reaction of *meso-cis*-cyclohexene oxide with *dl-cis*-2-aminocyclohexanol. The stereospecificity of the latter reaction indicates that II is *dl-trans-cis*-2,2'-dihydroxydicyclohexylamine and, therefore, that VIII is the corresponding *N*-benzoyl derivative.

(4) M. Mousseron, R. Granger, G. Combes and V. A. Pertzoff, *Bull. soc. chim. France*, 859 (1947).

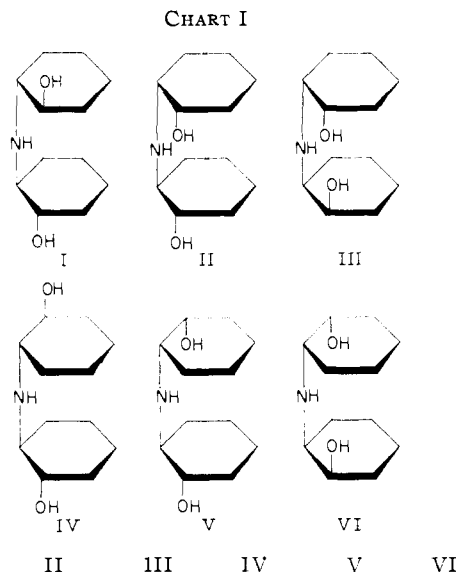

I, *meso-trans-trans*-2,2'-dihydroxydicyclohexylamine
II, *dl-trans-cis*-2,2'-dihydroxydicyclohexylamine
III, *meso-cis-cis*-2,2'-dihydroxydicyclohexylamine
IV, *dl-trans-trans*-2,2'-dihydroxydicyclohexylamine
V, *dl-trans-cis*-2,2'-dihydroxydicyclohexylamine
VI, *dl-cis-cis*-2,2'-dihydroxydicyclohexylamine

six diastereoisomers,² of which two are *meso* and four racemic as shown in Chart I.

Of the six compensated isomers, two (m.p. 153° and 114°) were prepared by Brunel³ on treatment

(1) Studies in Stereochemistry. XV.

(2) There exist two *dl-trans-cis*-isomers which are difficult to distinguish by the nomenclature adopted here. They are pictured in perspective formulas II and V as shown in Chart I. The molecules are drawn so that the average planes of the two cyclohexane rings are in the *syn*-relationship to C_1-N-C_1' and at right angles to the plane of the paper; C_1 , N, C_1' , C_4 and C_4' are bisected by the plane of the paper. Then in II the two hydroxy groups are situated on the same side of the plane of the paper, while in V they are on different sides.

(3) L. Brunel, *Compt. rend.*, **137**, 199 (1903).

CHART II

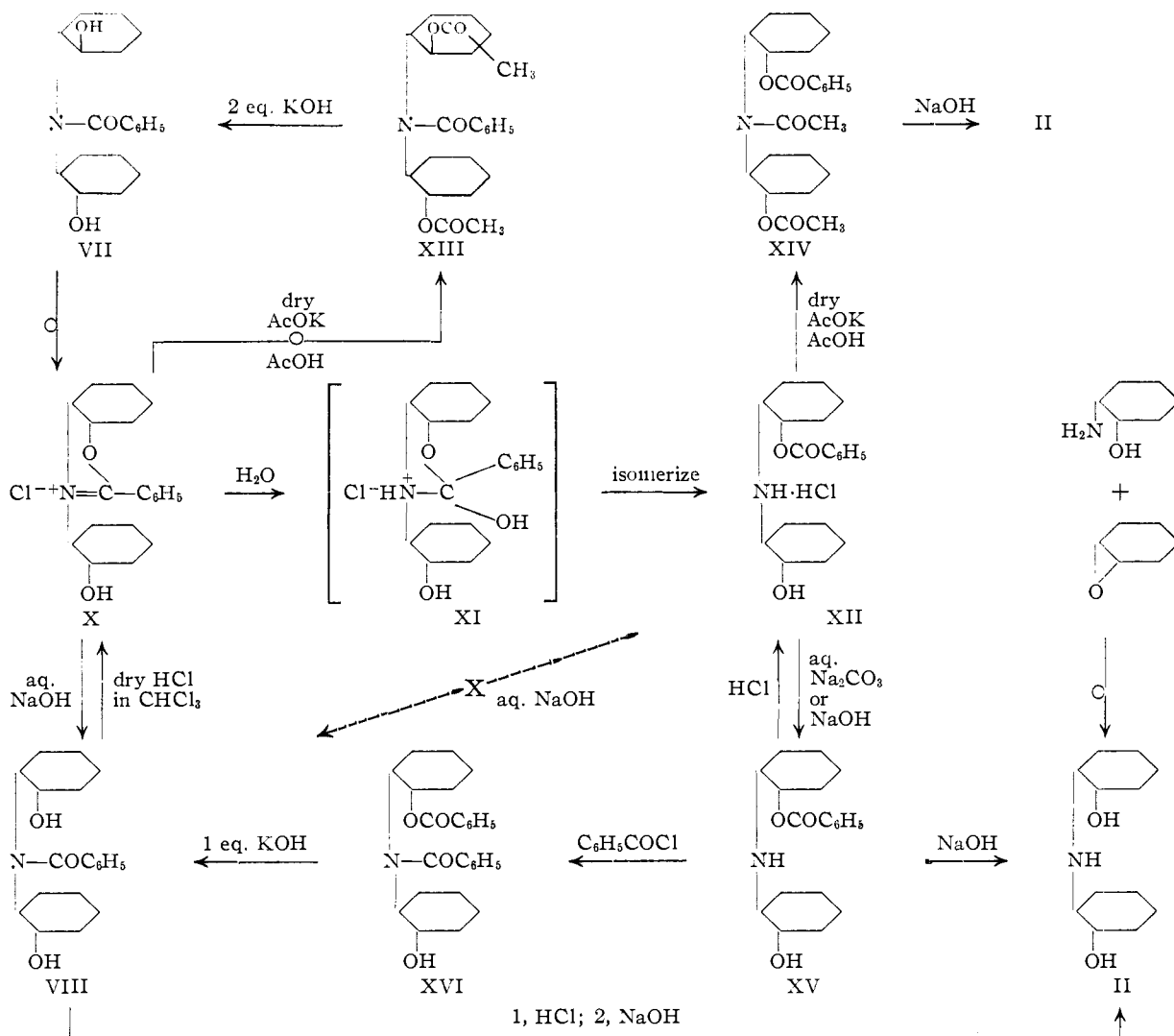

The Walden inversion of VII was examined further. As described in the Experimental section two picrates were prepared from the reaction mixture; one, m.p. 150° , was identical with the picrate of the O-benzoyl-*trans-cis*-aminodiol XII, and the other, m.p. 130° was eventually shown to be the picrate derived from the oxazolinium salt X. The identification of X is based on the following facts: treatment of the N-benzoyl-*trans-cis*-aminodiol VIII with dry hydrogen chloride gave a product (X), $\text{C}_{19}\text{H}_{26}\text{NO}_2\text{Cl}$, which contained the $>\text{C}=\text{N}^+<$ linkage as shown by its infrared absorption spectrum ($\lambda_{\text{max}}^{\text{Nujol}}$ 6.20μ).⁵ This suggested that X is *dl*-3-(*trans*-2'-hydroxycyclohexyl)-2-phenyl-*cis*-4,5-cyclohexano-oxazolinium chloride.⁶ Fur-

ther evidence was supplied by the formation of *meso*-(*trans-trans*-2,2'-diacetoxydicyclohexyl)-benzoylamine (XIII) with inversion when X was treated with dry potassium acetate-acetic acid. In contrast, we observed the formation of *dl*-(*trans*-2-acetoxy-*cis*-2'-benzoyloxydicyclohexyl)-acetylamine (XIV) without inversion by the similar treatment of the O-benzoyl-*trans-cis*-aminodiol XII. Upon hydrolysis with aqueous alkali the former triacyl compound XIII reverted to the N-benzoyl-*trans-trans*-aminodiol VII, and the latter triacyl compound XIV gave the *trans-cis*-aminodiol II.

The oxazolinium picrate X' derived from its chloride X was identical with the picrate (m.p. 130°) isolated from the thionyl chloride-VII reaction mixture; this indicates that the reaction VII \rightarrow XII, involving the Walden inversion, proceeds through the oxazolinium salt. Treatment of XII with aqueous sodium carbonate or sodium hydroxide did not effect acyl migration from O to N, but McCasland and D. A. Smith, *ibid.*, **72**, 2190 (1950); S. Winstein and R. Boschan, *ibid.*, **72**, 4669 (1950); W. S. Johnson and E. N. Schubert, *ibid.*, **72**, 2187 (1950).

(5) L. J. Bellamy, "The Infrared Spectra of Complex Molecules," John Wiley and Sons, Inc., New York, N. Y., 1954, p. 227.

(6) It is noteworthy that X is comparatively stable, although N-substituted oxazolinium salts are generally believed to be so unstable that they cannot be isolated; see T. Taguchi and M. Kojima, *Pharm. Bull. (Japan)*, **1**, 325 (1953); K. Tanaka, *J. Pharm. Soc. Japan*, **70**, 216 (1950); S. Ikuma, *ibid.*, **72**, 953 (1952); E. M. Fry, *J. Org. Chem.*, **19**, 887 (1949); J. Attenburrow, D. F. Elliott and G. F. Penny, *J. Chem. Soc.*, 310 (1948); K. Pfister, 3rd., C. A. Robinson, A. C. Shabica and M. Tishler, *THIS JOURNAL*, **71**, 1101 (1949); G. E.

gave the free base XV, which showed no change even after boiling in benzene; prolonged treatment with sodium hydroxide resulted in hydrolysis of XV to the *dl-trans-cis*-aminodiol II. Thus the *N*-benzoyl-*trans-cis*-aminodiol VIII was not derived from XII by O → N acyl migration, but was formed when the oxazolinium salt X was treated with aqueous sodium hydroxide.

meso-cis-cis-2,2'-Dihydroxycyclohexylamine (III) was obtained in the following way (see Chart III). The *N*-benzoyl-*trans-cis*-aminodiol VIII reacted with thionyl chloride to give the hydrochloride of a basic substance XVIII and a neutral substance XIX. It was postulated that XVIII is *dl-cis-2*-benzoyloxy-*cis-2'*-hydroxycyclohexylamine hydrochloride on the basis of the reaction sequence and of the fact that XVIII was hydrolyzed by aqueous potassium hydroxide to the aminodiol III; this also served to establish the identity of III as an epimer different from I and II.

The following findings suggest that the neutral substance is XIX: it was converted to the *O*-benzoyl-*cis-cis*-aminodiol hydrochloride XVIII on boiling in water, and to the *cis-cis*-aminodiol III on boiling in dilute hydrochloric acid followed by treatment with alkali; the replacement of a chlorine by an hydroxy group would presumably be accompanied by inversion.

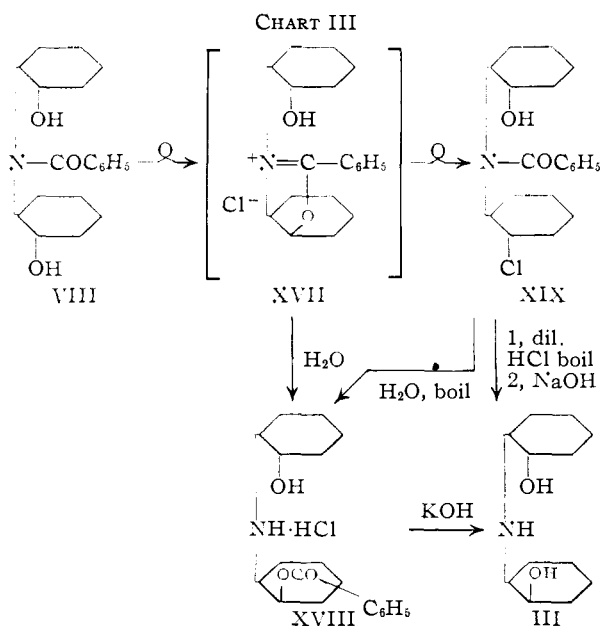

In regard to the reaction mechanism, it was postulated that the treatment of the *N*-benzoyl-*trans-cis*-aminodiol VIII with thionyl chloride might give *dl-3-(cis-2'-hydroxycyclohexyl)-2-phenyl-cis-4,5-cyclohexano*oxazolinium chloride (XVII) as an intermediate; XVII was then converted by hydrolytic ring-opening to XVIII with retention of configuration, or by internal attack of the chloride ion to XIX with inversion of configuration.

In the course of this study our attention was directed to the *N*-benzoylation of epimeric 2,2'-dihydroxycyclohexylamines. As mentioned above, the *trans-trans*-epimer I underwent *N*-

benzoylation readily by the Schotten-Baumann method, while neither the *trans-cis*-epimer II nor the *cis-cis*-epimer III could be benzoylated by this method. However, XV, in which the *cis*-hydroxy group of the *trans-cis*-epimer II is replaced by an *O*-benzoyl group, underwent *N*-benzoylation, but *N*-benzoylation of the mono-*O*-benzoyl derivative of the *cis-cis*-epimer III was unsuccessful. Thus, *N*-benzoylation was not possible if the molecule had a hydroxy group in *cis* position to the amino group.

This phenomenon presumably might be explained in terms of the relatively strong hydrogen bond between the *cis*-hydroxy group and the nitrogen; this would result in a decrease in the electron density of the nitrogen and thus in inhibition of *N*-benzoylation. We have found that this type of hydrogen bond is stronger in *dl-cis-2*-aminocyclohexanol than in the *trans*-epimer,⁷ and that *N*-alkylation of the *cis*-epimer is somewhat suppressed; the *trans*-epimer underwent dialkylation, while under the same conditions only monoalkylation of the *cis*-epimer was possible⁸.

Experimental⁹

meso-trans-trans-2,2'-Dihydroxycyclohexylamine (I).—A mixture of 100 g. of *meso-cis*-cyclohexene oxide and 60 ml. of aqueous ammonia (28%) was kept at room temperature for a week; the precipitate was collected,¹⁰ washed with water, dried (yield 53.5 g.) and recrystallized from ethanol as colorless prisms, m.p. 153°. On admixture with an authentic sample prepared by Mousseron's procedure⁴ the melting point was unchanged.

Anal. Calcd. for C₁₂H₂₃NO₂: C, 67.56; H, 10.87; N, 6.57. Found: C, 67.89; H, 10.75; N, 6.36.

meso-(trans-trans-2,2'-Dihydroxycyclohexyl)-benzoylamine (VII).—(a) To 500 ml. of an aqueous solution containing 140 ml. of 10% hydrochloric acid and 77 g. of the *meso-trans-trans*-aminodiol I was added a solution of 70 g. of benzoyl chloride in 100 ml. of benzene, then 200 ml. of 35% aqueous sodium hydroxide was added dropwise. The resulting precipitate was washed with 200 ml. of hot water, dried (yield 81 g.) and recrystallized from ethanol as colorless prisms, m.p. 231–232°.

Anal. Calcd. for C₁₉H₂₇NO₃: C, 71.92; H, 8.58; N, 4.41. Found: C, 71.66; H, 8.34; N, 4.36.

dl-(trans-cis-2,2'-Dihydroxycyclohexyl)-benzoylamine (VIII).—To 40 ml. of thionyl chloride was added 43 g. of the *N*-benzoyl-*trans-trans*-aminodiol VII (which had been ground in a mortar) in small portions with cooling; more thionyl chloride (10 ml.) was added to dissolve a small amount of material. After three hours¹¹ the mixture was poured into 200 ml. of cold water and filtered.¹² The filtrate was rapidly cooled and immediately adjusted to pH 14.0 with 10% aqueous sodium hydroxide. The resulting oily product, after standing overnight, crystallized upon the addition of a small amount of ether. Recrystallization from benzene gave colorless plates, m.p. 196–197°, yield 27.7 g.

(7) This conclusion is based on the following data for the infrared spectra of these compounds: for the *trans*-form, $\lambda_{\text{max}}^{\text{Nujol}}$ 6.30 μ (amino) and 9.30 μ (hydroxy); for the *cis*-form, $\lambda_{\text{max}}^{\text{Nujol}}$ 6.17 μ (amino) and no absorption at 9.30 μ . See also E. D. Bergmann, E. Gil-av and S. Pinchas, *THIS JOURNAL*, **75**, 68 (1953).

(8) For ethylation, see T. Taguchi and M. Nakayama, *THIS JOURNAL*, **73**, 5679 (1951). The results of other alkylations will be reported.

(9) All melting points are uncorrected.

(10) The filtrate was concentrated *in vacuo* to leave an oily product which crystallized gradually; yield 29 g. This product was shown to be *dl-trans-2*-aminocyclohexanol by a mixed melting point determination.

(11) When the residue was washed with ether after removal of excess thionyl chloride, there remained mainly an amine hydrochloride of m.p. 165° dec. which has not been identified.

(12) When the acidic filtrate was kept at room temperature for a week, crystals appeared which were identified as *dl-trans-2*-hydroxy-*cis-2'*-benzoyloxydicyclohexylamine hydrochloride (XII).

Anal. Calcd. for $C_{19}H_{27}NO_3$: C, 71.92; H, 8.58; N, 4.41. Found: C, 71.54; H, 8.34; N, 4.54.

dl-3-(*trans*-2'-Hydroxycyclohexyl)-2-phenyl-*cis*-4,5-cyclohexano δ xazolinium Salts. (a) Hydrochloride X.—A solution of 500 mg. of the N-benzoyl *dl*-*trans*-*cis*-aminodiol VIII in 30 ml. of anhydrous chloroform was saturated with dry hydrogen chloride at 0°. After standing for an hour in the cold, the solution was concentrated. Upon the addition of a large volume of dry ether the resulting oily residue crystallized gradually as hygroscopic colorless crystals, m.p. 149–153° dec., yield quantitative; infrared absorption spectrum: λ_{max}^{NaCl} 6.20 ($>C=N^+<$), 7.90 (ester) and 9.32 μ (hydroxy).

(b) Picrate X'.—To an aqueous solution of X was added a saturated aqueous solution of sodium picrate. The precipitate was recrystallized from acetone-ether¹³ as yellow needles, m.p. 130°.

Anal. Calcd. for $C_{19}H_{26}NO_2 \cdot C_6H_2N_3O_7$: C, 56.81; H, 5.33; N, 10.60. Found: C, 57.20; H, 5.07; N, 10.41.

dl-*trans*-2-Hydroxy-*cis*-2'-benzoyloxydicyclohexylamine Hydrochloride (XII).—On standing in air the oxazolinium chloride X gradually absorbed moisture and then solidified. Recrystallization from water gave colorless prisms, m.p. 224–226° dec.; λ_{max}^{NaCl} 3.08 (hydroxy), 5.84 (ester carbonyl), 7.82 (ester), 8.95 (ester) and 9.07 μ (phenyl).

Anal. Calcd. for $C_{19}H_{27}NO_3 \cdot HCl$: C, 64.48; H, 7.97; N, 3.96. Found: C, 64.55; H, 7.93; N, 4.20.

The hydrochloride XII was converted to the picrate by the usual method and recrystallized from ethanol; m.p. 150°.

Anal. Calcd. for $C_{19}H_{27}NO_3 \cdot C_6H_2N_3O_7$: C, 54.94; H, 5.51; N, 10.25. Found: C, 55.07; H, 5.62; N, 10.21.

dl-*trans*-2-Hydroxy-*cis*-2'-benzoyloxydicyclohexylamine (XV).—An aqueous solution of the hydrochloride XII was made alkaline with 10% aqueous sodium carbonate; the resulting oily product which crystallized was recrystallized from benzene as colorless plates (XV), m.p. 79°, which gave a negative Beilstein test for halogen.

Anal. Calcd. for $C_{19}H_{27}NO_3$: C, 71.89; H, 8.58; N, 4.41. Found: C, 71.80; H, 8.61; N, 4.93.

Treatment of XV with hydrogen chloride gave reversibly the hydrochloride XII which was converted to the picrate, m.p. and mixed m.p. 150°.

Treatment of XII with 10% aqueous sodium hydroxide also gave XV which crystallized upon the addition of a small amount of ether to the oily product; m.p. and mixed m.p. 79°. However, if the alkaline solution was kept for a few days, the oily product solidified; after filtration, recrystallization from benzene gave colorless needles, m.p. 147°, which were identified by a mixed melting point determination as the *trans*-*cis*-aminodiol II.

meso-(*trans*-*trans*-2,2'-Diacetoxydicyclohexyl)-benzoylamine (XIII).—To mixture of 1.0 g. of anhydrous potassium acetate, 5.0 g. of dry acetic acid and 1.0 g. of acetic anhydride, which had been refluxed for 10 minutes, was added 600 mg. of the oxazolinium chloride X. The reaction mixture was boiled for 15 minutes and then concentrated *in vacuo* to dryness. The residue was extracted with ethyl acetate, washed with saturated sodium bicarbonate solution and then with water, dried and concentrated. The residue after repeated recrystallization from benzene-petroleum ether and finally from ether, gave colorless plates of XIII, m.p. 143–147°, yield 300 mg.

Anal. Calcd. for $C_{23}H_{31}NO_5$: C, 68.80; H, 7.78; N, 3.49. Found: C, 68.69; H, 7.76; N, 3.97.

From the combined recrystallization filtrates, colorless prisms were obtained (m.p. 152–153°, yield 50 mg.) which were identified as XIV.

A solution of 100 mg. of XIII in 1.5 ml. of ethanol containing 25 mg. of potassium hydroxide (2.2 equivalents) and one drop of water, was kept at room temperature overnight. The solution (pH 7.4) was concentrated *in vacuo* to give colorless prisms which were washed with water, dried (yield 60 mg.) and recrystallized from ethanol; m.p. 232°. This product was identified as VII by a mixed melting point determination.

(13) Alcohol is not recommended for recrystallization because the product is converted to the O-benzoyl-*trans*-*cis*-aminodiol picrate (XV-picrate).

dl-(*trans*-2-Acetoxy-*cis*-2'-benzoyloxydicyclohexyl)-acetylamine (XIV).—The O-benzoyl-*trans*-*cis*-aminodiol hydrochloride XII was acetylated as described for the preparation of XIII. Recrystallization from benzene-petroleum ether gave colorless plates, m.p. 152–153.5°.

Anal. Calcd. for $C_{23}H_{31}NO_5$: C, 68.80; H, 7.78; N, 3.49. Found: C, 68.86; H, 7.61; N, 3.89.

dl-(*trans*-2-Hydroxy-*cis*-2'-benzoyloxydicyclohexyl)-benzoylamine (XVI).—Benzoylation of 1.0 g. of the O-benzoyl-*trans*-*cis*-aminodiol hydrochloride XII by the Schotten-Baumann method yielded an oily product which was kept in 10 ml. of water overnight and then crystallized by the addition of ether. Recrystallization from methanol-petroleum ether gave colorless plates of XVI, m.p. 147–148°, yield 550 mg.

Anal. Calcd. for $C_{26}H_{31}NO_4$: C, 74.08; H, 7.41; N, 3.32. Found: C, 74.19; H, 7.24; N, 3.42.

Partial hydrolysis of XVI with a slight excess of potassium hydroxide gave the N-benzoyl-*trans*-*cis*-aminodiol VIII, m.p. and mixed m.p. 197°.

dl-*trans*-*cis*-Dihydroxydicyclohexylamine (II).—(a) A solution of 500 mg. of *dl*-*cis*-2-aminocyclohexanol and 500 mg. of *meso*-*cis*-cyclohexene oxide in 5 ml. of methanol was kept at room temperature for ten days, and then concentrated to a small volume. The resulting solid was recrystallized from benzene as colorless needles of II, m.p. 147°.

Anal. Calcd. for $C_{12}H_{23}NO_2$: C, 67.56; H, 10.86; N, 6.57. Found: C, 67.60; H, 10.73; N, 6.35.

(b) A mixture of 500 mg. of the N-benzoyl-*trans*-*cis*-aminodiol VIII and 20 ml. of 10% hydrochloric acid was boiled for five hours. The precipitated benzoic acid was filtered, and the filtrate was evaporated *in vacuo* to give a solid which was washed with acetone (yield 190 mg.). Recrystallization from methanol gave colorless prisms of the hydrochloride of II, m.p. 237–239° dec.

Anal. Calcd. for $C_{12}H_{23}NO_2 \cdot HCl$ (II-HCl): C, 57.70; H, 9.68; N, 5.61. Found: C, 57.68; H, 9.18; N, 5.49.

This hydrochloride was converted to II by treatment of its aqueous solution with 10% sodium hydroxide. The product melted at 147° alone and mixed with a sample of II prepared by procedure (a).

(c) A solution of 50 mg. of XIV, the N,O,O-triacyl derivative of the *trans*-*cis*-aminodiol, in 3 ml. of ethanol containing 50 mg. of sodium hydroxide and 0.05 ml. of water was boiled for an hour. Colorless needles separated on the addition of 15 ml. of water; yield 20 mg., m.p. and mixed m.p. 147°.

(d) II was obtained from the O-benzoyl-*dl*-*trans*-*cis*-aminodiol hydrochloride XII on treatment with sodium hydroxide for two days, as mentioned above.

Action of Thionyl Chloride on *meso*-(*trans*-*trans*-2,2'-Dihydroxydicyclohexyl)-benzoylamine (VII). The isolation of *dl*-3-(*trans*-2'-Hydroxycyclohexyl)-2-phenyl-*cis*-4,5-cyclohexano δ xazolinium Picrate (X') and *dl*-*trans*-2-Hydroxy-*cis*-2'-benzoyloxydicyclohexylamine Picrate (XII').—Compound VII (1.0 g.) was treated with 1 ml. of thionyl chloride as previously described. After three hours the solution was poured into 10 ml. of water and filtered. The filtrate was concentrated immediately *in vacuo*, and the resulting oily product was converted to the picrate by the usual method; m.p. 122–128°, yield 1.5 g. The picrate was added to 10 ml. of dry acetone and filtered; yield of yellow residue 650 mg., m.p. 135°. Recrystallization from ethanol gave yellow plates, m.p. 150° alone and on admixture with an authentic sample of XII'. The acetone filtrate was concentrated to 2 ml. and the picrate precipitated by the addition of dry ether; m.p. 128°, yield 700 mg. Recrystallization from acetone-ether gave yellow needles, m.p. 130° alone and on admixture with an authentic sample of X'.

dl-*cis*-2-Benzoyloxy-*cis*-2'-hydroxydicyclohexylamine Hydrochloride (XVIII) and *dl*-(*trans*-2-Chloro-*cis*-2'-hydroxydicyclohexyl)-benzoylamine (XIX).—Compound VIII (4.7 g.) was treated with 5.5 ml. of thionyl chloride, and the reaction mixture treated essentially as described for the preparation of VIII from VII. The oily product, after standing overnight at room temperature, was extracted with ether, washed with water and extracted twice with 20 ml. of 5% aqueous hydrochloric acid. The acid extract was washed with ether and evaporated to dryness. The residue, which crystallized in a desiccator, was recrystallized from water as colorless cubes of XVIII, m.p. 201–203° dec.

Anal. Calcd. for $C_{19}H_{27}NO_3 \cdot HCl$ (XVIII): C, 64.48; H, 7.97; N, 3.96. Found: C, 64.58; H, 7.83; N, 3.65.

The dried ether layer was evaporated to dryness and the residue recrystallized from methanol to give colorless plates (m.p. 134–135°, yield 0.8 g.) which gave a positive Beilstein test for halogen; the test remained positive even after treatment of the compound with aqueous sodium hydroxide; λ_{max}^{Nujol} 3.04 (hydroxy), 6.24 (amido?), 7.59 (hydroxy), 8.98 (hydroxy), 13.44 and 13.80 μ (one of which is chloro). Treatment of XIX with boiling water gave XVIII.

Anal. Calcd. for $C_{19}H_{26}NO_2Cl$ (XIX): C, 67.94; H, 7.80; N, 4.17; Cl, 10.56. Found: C, 67.73; H, 7.47; N, 4.08; Cl, 10.26.

meso-cis-cis-Dihydroxydicyclohexylamine (III).—Treatment of an aqueous solution of the amine hydrochloride XVIII with 10% sodium hydroxide yielded *dl-cis-2-benzoyloxy-cis-2'-hydroxydicyclohexylamine* (XX) which gave a negative Beilstein test for halogen; m.p. 56–59°; λ_{max}^{Nujol} 3.20 (hydroxy), 5.84 (ester carbonyl), 7.86 (ester) and 9.05 μ (ester).

Anal. Calcd. for $C_{19}H_{27}NO_3$: C, 71.89; H, 8.58; N, 4.41. Found: C, 71.67; H, 8.76; N, 4.18.

Compound XX was further hydrolyzed by a solution containing 1.2 equivalents of potassium hydroxide to give the *meso-cis-cis-aminodiol* III, m.p. 101°; see the procedure for the hydrolysis of XIII to VII.

Anal. Calcd. for $C_{12}H_{23}NO_2$: C, 67.56; H, 10.86; N, 6.57. Found: C, 67.70; H, 10.86; N, 6.30.

Compound III showed a depression of m.p. on admixture with the *meso-trans-trans-aminodiol* I or the *dl-trans-cis-aminodiol* II.

Acknowledgments.—We wish to express our gratitude to the Microanalytical Laboratory of this Institute for the microanalyses, and to Mr. Ueda and Mr. Matsui of this Institute and to the Sankyo Co. for the infrared spectra.

KATAKASU, FUKUOKA, JAPAN

[CONTRIBUTION FROM THE CHEMICAL LABORATORY OF NORTHWESTERN UNIVERSITY]

Behavior of Kojic Acid toward Acrylonitrile, Halo Acids and Hydrogen Cyanide

BY CHARLES D. HURD AND SWIATOSLAW TROFIMENKO

RECEIVED JANUARY 22, 1958

The published reactions of kojic acid with acrylonitrile or sodium 3-bromopropionate or potassium cyanide followed by acidification are open to question. The products cited were shown to be kojic acid. Kojyloxyacetic¹ acid was formed from sodium kojate and sodium bromoacetate. Infrared peaks for kojic acid in potassium bromide are presented.

In a recent article, Woods² stated that cyanoethylation of kojic acid in dioxane occurred on prolonged refluxing (19 hours) with acrylonitrile in the presence of a basic catalyst. The product was not isolated as such but was hydrolyzed by long boiling with dilute hydrochloric acid to yield an acid of m.p. 155°, regarded to be 6-(2-carboxyethyl)-kojic acid (I).

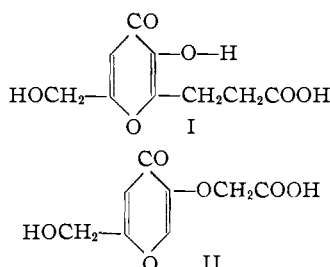

Prior to this work one of us (C.D.H.) also had studied the behavior of kojic acid toward acrylonitrile but since no such new compound was obtained, Woods' work was repeated. By following his directions as carefully as possible nothing was obtained except a black tarry product. From the latter some yellowish-orange sirup, but nothing crystalline, was obtained by extraction with isopropyl alcohol or with a 1:1 mixture of ethyl acetate and ethanol. Possibly some unused kojic acid was present, but we found none. Thus, in our hands decomposition did occur in these operations but no evidence for the simple crystalline product described by Woods could be obtained.

Woods later reported³ formation of the same acid, m.p. 152°, by long refluxing of a mixture of kojic

acid, alcohol and sodium 3-bromopropionate (actually, bromopropionic acid + $NaHCO_3$) and stated that the acids formed by the two methods gave identical acetyl and *p*-bromophenacyl derivatives.

We repeated this experiment and obtained complete agreement with the reported findings, but we interpreted the results quite differently. The white crystals obtained at the end of the operations melted at 152° and were considerably different in appearance from the original kojic acid, but its identity to kojic acid was attested to by its m.p. 152°, by no m.p. depression when mixed with authentic kojic acid and by the absence of carboxyl when tested with Davidson indicator.⁴ Its infrared spectrum (Baird double beam spectrophotometer, employing a pellet of potassium bromide as the medium) was in complete agreement with one previously taken on an authentic sample of kojic acid. Both samples showed these peaks: two strong hydroxyl peaks, partly fused, at 3.08 and 3.16; weak peaks at 3.41, 3.51 and 5.88; the strong pyrone system at 6.04, 6.10 and 6.17 (the last two fused, yet sharp) and 6.29; also, weak peaks at 6.78, 6.92, and 7.16; medium at 7.40 and 7.78; strong at 8.12 (shoulder at 8.03), 8.42w, 8.72s, 9.28s, 10.10w, 10.59s, 11.55s, 11.70w, 12.85m, 13.00 (broad and fused), followed by a wide hump around 15.70 μ . This agrees also with a published infrared spectrum⁵ of kojic acid.

Since Woods stated that his two compounds (ref. 2 and 3) were identical and since we have established that the material of ref. 3 is kojic acid, then it follows that the acid of ref. 2 must also have

(1) The acyl radical of kojic acid, $C_6H_7O_3OH$, is $C_6H_5O_3$ or kojyl, analogous to picryl from picric acid.

(2) L. I. Woods, *THIS JOURNAL*, **74**, 3959 (1952).

(3) L. L. Woods, *ibid.*, **75**, 1510 (1953).

(4) D. Davidson, *J. Chem. Educ.*, **19**, 221, 582 (1942).

(5) I. P. Kuhn, *Anal. Chem.*, **22**, 276 (1950).